

# Submittal Data

## Series 750 LTX

### Low Intensity Infrared Heaters



**SUPERIOR**  
RADIANT PRODUCTS

Project \_\_\_\_\_  
 Engineer \_\_\_\_\_  
 Contractor \_\_\_\_\_  
 Model # \_\_\_\_\_

Date: \_\_\_\_\_  
 Submitted by: \_\_\_\_\_  
 Approved by: \_\_\_\_\_

### General Specification

<b>Fuel Type</b> Natural Gas	<b>Heat Exchanger</b> Coated Heat Treated Aluminized Steel
<b>Inlet Gas Pressure</b> Minimum Natural Gas @ 5" W.C. Maximum Natural Gas @ 14" W.C.	<b>Electrical:</b> <i>(Select thermostat)</i> 120VAC, 60 Hz, 1A 30" long, 3 Prong Power Lead ___ Line Voltage ___ 24v Thermostat
<b>Manifold Gas Pressure</b> Nat. Gas 3.5" W.C.	<b>Flue/Air Connections</b> 4" Diameter Connection Maximum Vent Length = 30 feet Maximum fresh Air Length = 30 feet Vent + Fresh Air = 50 feet max.
<b>Gas Connection</b> 1/2" NPT (female)	

<b>Accessories</b> <i>(Check all that apply)</i>
Thermostat Vent Terminal Wall Thimble Gas Flex Connector Shut Off Valve U Bend Pkg. Side Reflectors Flue Connecting Tee (4x4x6)

MODEL	RATE BTUH	FACTORY APPROVED HEATER LENGTH		PROJECT MODIFICATION	Quantity on Project
		<i>(Check length - feet)</i>			
LTX-60/45	60,000 High 45,000 Low	30	40		
LTX-100/75	100,000 High 75,000 Low	60			



# Introduction

---

Superior Radiant offers its 20 years of infrared expertise in a cost effective unitary heater design as culmination of that commitment. Series 750 LTX models are field assembled, low intensity infrared heaters that are easy to install and maintain, and which were engineered with significant input from our customers. They are designed to provide economical operation and trouble-free service for years to come.

This document is for submittal purpose only and should in no way replace the installation and operation manual.

## Installation Codes

Installations must comply with local building codes, or in their absence, the latest edition of the national regulations and procedures as listed below.

### *General Installation and Gas Codes*

Heaters must be installed only for use with the type of gas appearing on the rating plate, and the installation must conform to the National Fuel Gas Code, ANSI Z223.1/NFPA 54 in US, CAN/CGA B149.1 and B149.2 in Canada

### *Gas Supply Lines*

Gas supply pipe sizing must be in accordance with the National Fuel Gas Code, ANSI Z223.1/NFPA 54 in US, CAN/CGA B149.1 and B149.2 in Canada. A 1/8" inch NPT plugged tap must be installed in the gas line connection immediately upstream of the burner farthest from the gas supply meter to allow checking of system gas pressure.

### *Electrical*

All heaters must be electrically grounded in accordance with the National Electric Code, ANSI/NFPA 70 in the US, CSA C22.1 in Canada.

### *Venting*

Refer to the National Fuel Gas Code, ANSI Z223.1/NFPA 54 in US, CGA B149.1 and 149.2 in Canada.

---

## General Specifications

---

### General Specifications

#### Gas Supply

##### *Inlet Pressure*

Natural Gas:	Minimum	5.0" W.C.
	Maximum	14.0" W.C.

##### *Manifold Pressure*

Natural Gas:	3.5" W.C.
--------------	-----------

##### *Inlet Connection*

Natural Gas:	1/2" female NPT
--------------	-----------------

---

#### Electric Supply

120 VAC, 60 HZ, 1 Amp: 36" cord with grounded 3 prong plug
--

---

#### Flue and Outside Air Connection

4" O.D. male connection for flue adapter and outside air (optional) provided at the heater
--

---

# Dimensional Charts

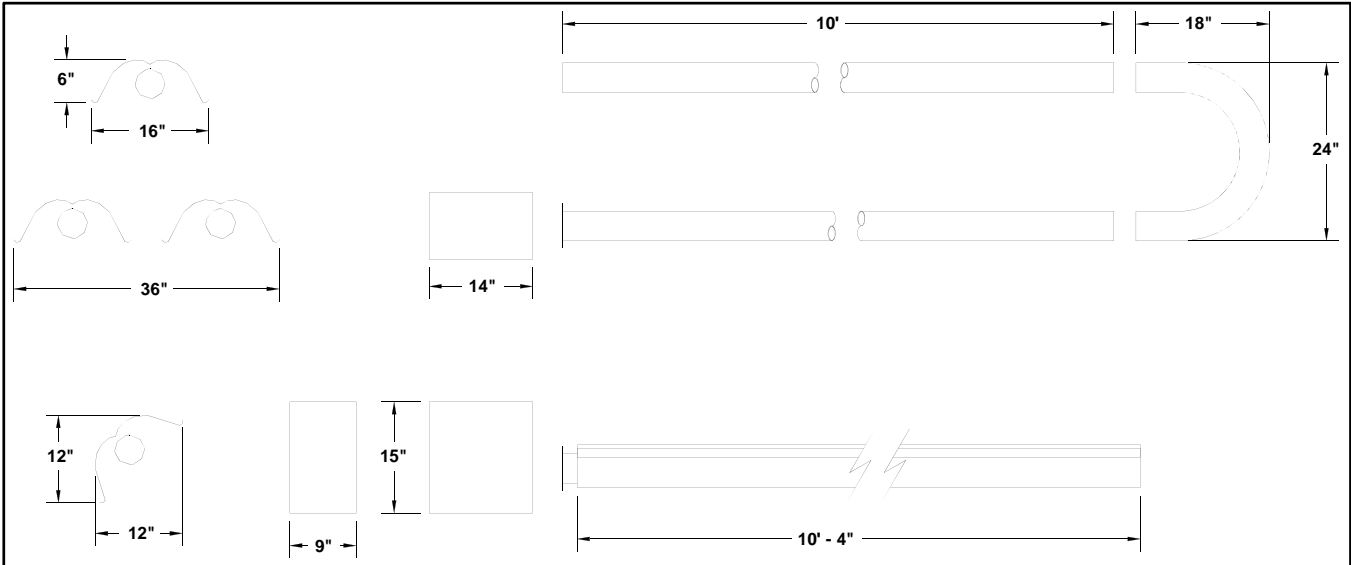

Figure 1: Overall Dimensional Information

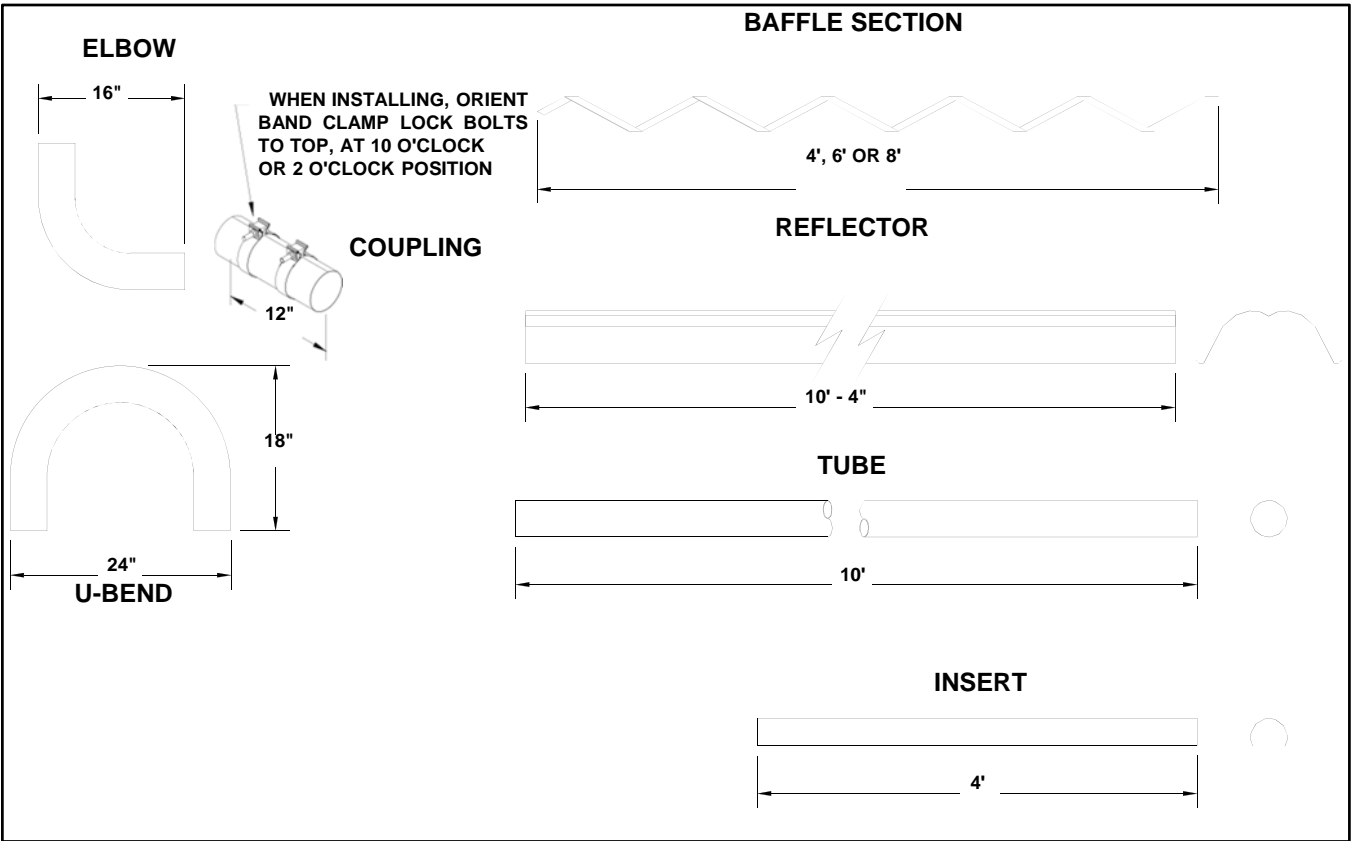

Figure 2: Component Dimensional Information

# Configurations

Model	High Rate (BTU/Hr)	Low Rate (BTU/Hr)	Heat Exchanger Length (ft.)		Baffle Length (ft.)
			Minimum	Maximum	
LTX-60	60,000	45,000	30'	40'	12'
LTX-100	100,000	75,000	60'		6'

Table 1: Configuration Information

**The following special configurations are also approved to comply with NFPA 30 A and NFPA 54 where maximum tube temperature is below 750°F.**

- 60,000 BTU/Hr      30 ft. or 40 ft. with 12 ft. baffle (2 – 6 ft sections, 1a luminized and 1 stainless). The first 3 tubes (30 ft.) are black coated. Part number for reference TH30LC. The remaining tubes will be heat treated aluminized (grey). Natural gas only.
- 100,000 BTU/Hr      60 ft. with 6 ft aluminized baffle. The first 3 tubes (30 ft.) are black coated. Part number for reference TH30LC. The remaining tubes will be heat treated aluminized (grey). Natural gas only.

**Insert should be factory , CHECK FOR ORIENTATION.**

To help keep the temperature down in the combustion tube, 2 different stainless steel inserts are installed. please refer to figure below 3a for more information. IT IS VERY IMPORTANT TO MAKE SURE PROPER INSTALLATION OF THE INSERTS

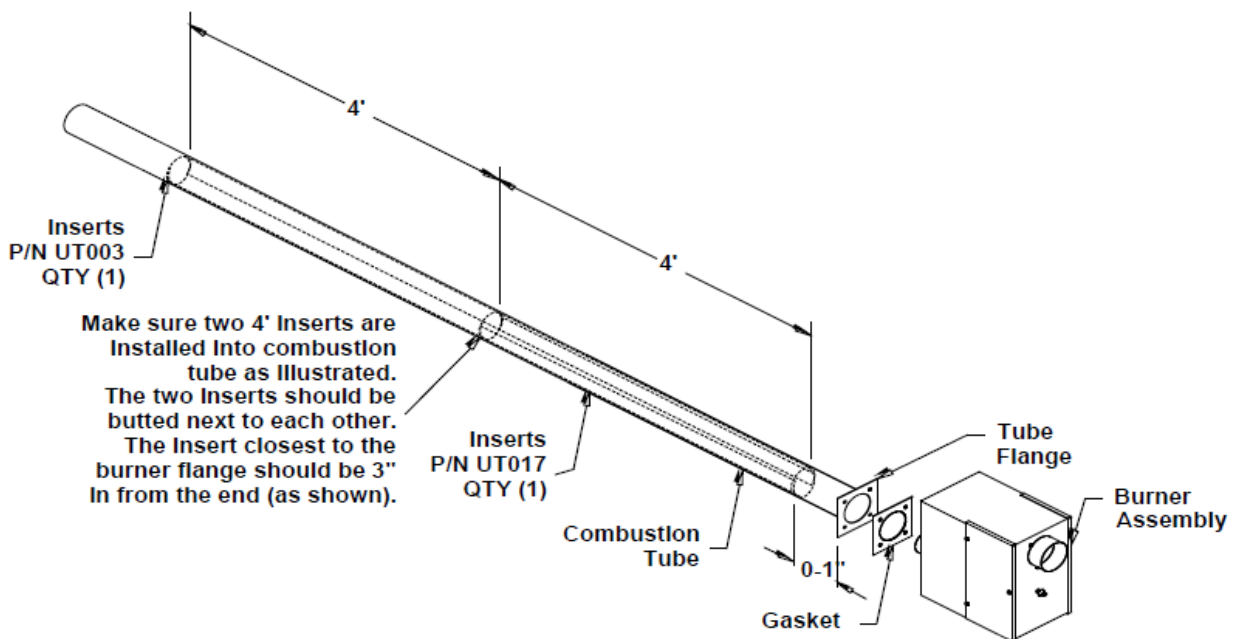
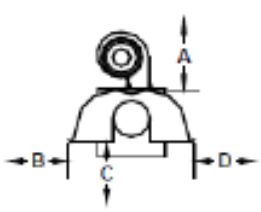
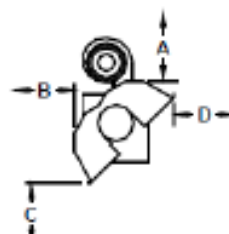
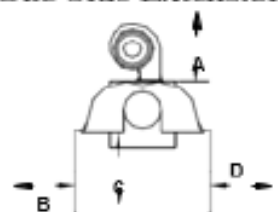
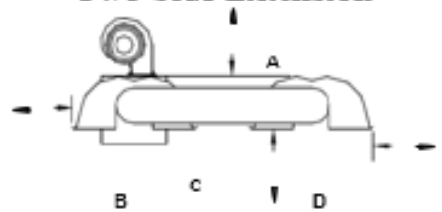
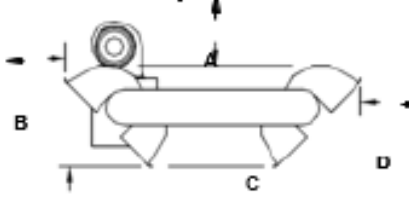

Figure 3: Stainless Steel Insert Installation

## Clearance to Combustibles

A general clearance of 18" (0.5 m) in every direction is recommended for servicing only around each Burner, Vacuum Pump, and End Vent Cap air supply (at the far end of each Radiant Branch) also to ensure adequate air flow in and around the Heating System.

**Table 2: Minimum Clearance to Combustibles - Model LA**

Reflector Configurations	Dim	60	100
<p style="text-align: center;">Horizontal</p> 	A	2"	2"
	B	4"	6"
	C	31"	36"
	D	4"	6"
<p style="text-align: center;">45° Reflector Tilt</p> 	A	3"	4"
	B	3"	3"
	C	18"	20"
	D	18"	20"
<p style="text-align: center;">One Side Extension</p> 	A	2"	2"
	B	2"	3"
	C	35"	36"
	D	6"	6"
<p style="text-align: center;">Two Side Extension</p> 	A	2"	2"
	B	2"	3"
	C	38"	38"
	D	2"	3"
<p style="text-align: center;">U-Tube, Horizontal</p> 	A	2"	2"
	B	4"	6"
	C	32"	38"
	D	4"	6"

Generally, there is no unique sequence for installation of the burner or heat exchanger. A review of the job site will usually indicate a logical installation order. However, time and expense can be saved if installation is begun at the most critical dimension, watching for interference from overhead doors, cranes, auto lifts etc. Figure 4 to Figure 6 provides a general overview of the components utilized in the installation, as well as their general relationship.

## LTX 60,000 BTU 30' Long

**For 40' heater follow the same sequence. The baffle is installed in the last section of the tube.**

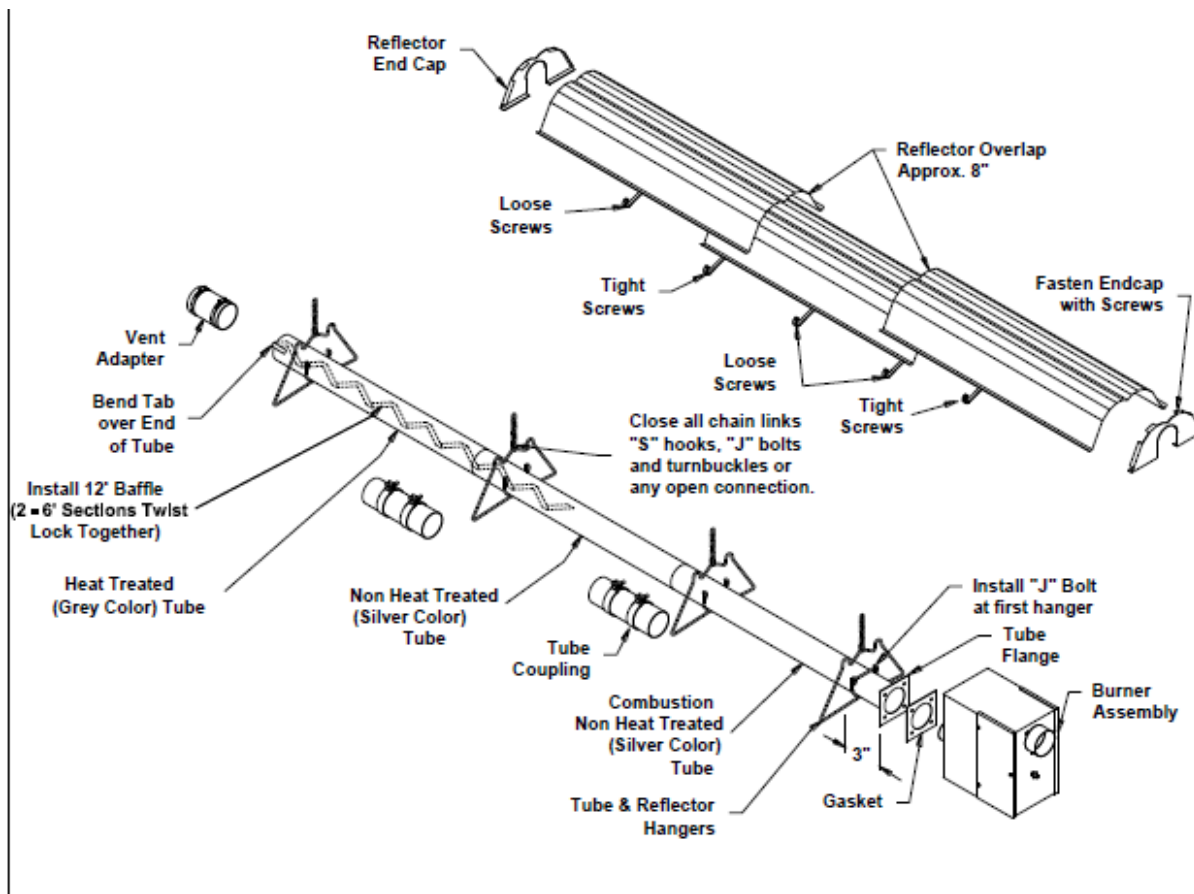

Figure 4: Installation Configurations for 60,000 BTU Model

# LTX 100,000 BTU 60' Long

For 60' Heater follow the same sequence. The baffles are installed in the last three sections of tube.

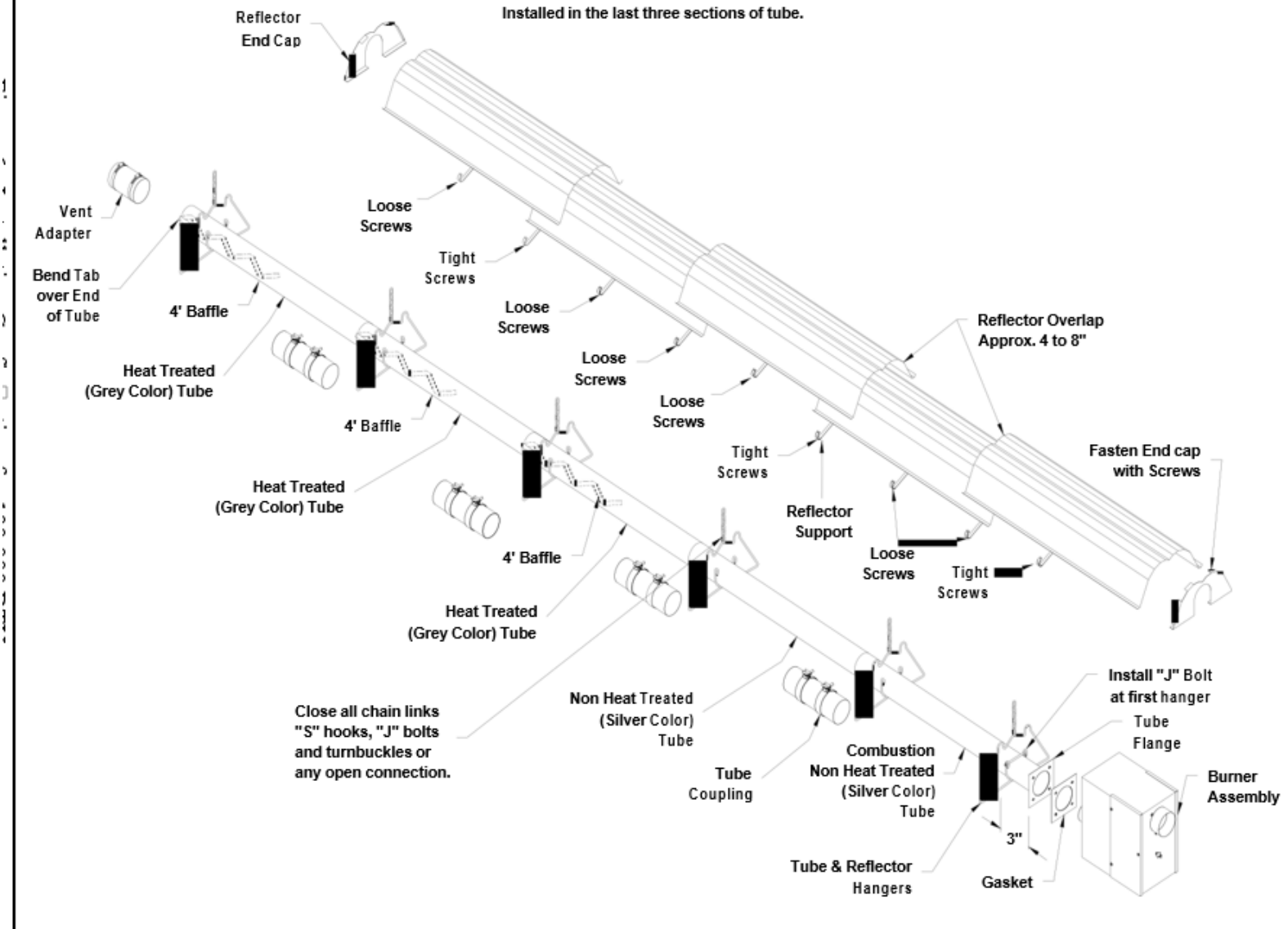
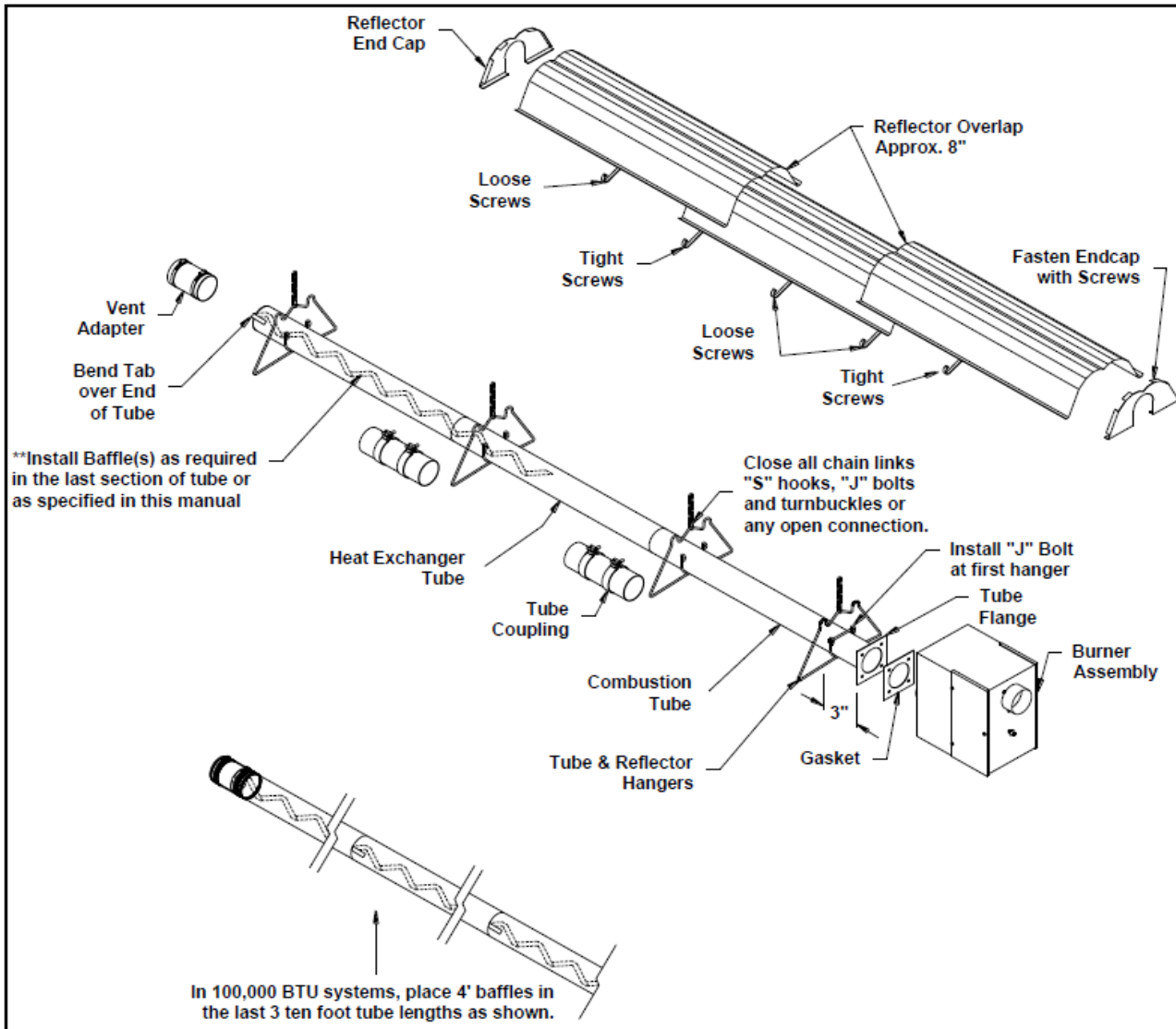

Figure 5: Installation Configuration for 100,000 BTU Model



# Installation

A general ordered sequence for installation is provided below for reference.



- A general overall view of the tubes and reflector hangers are shown in Figure 15 below

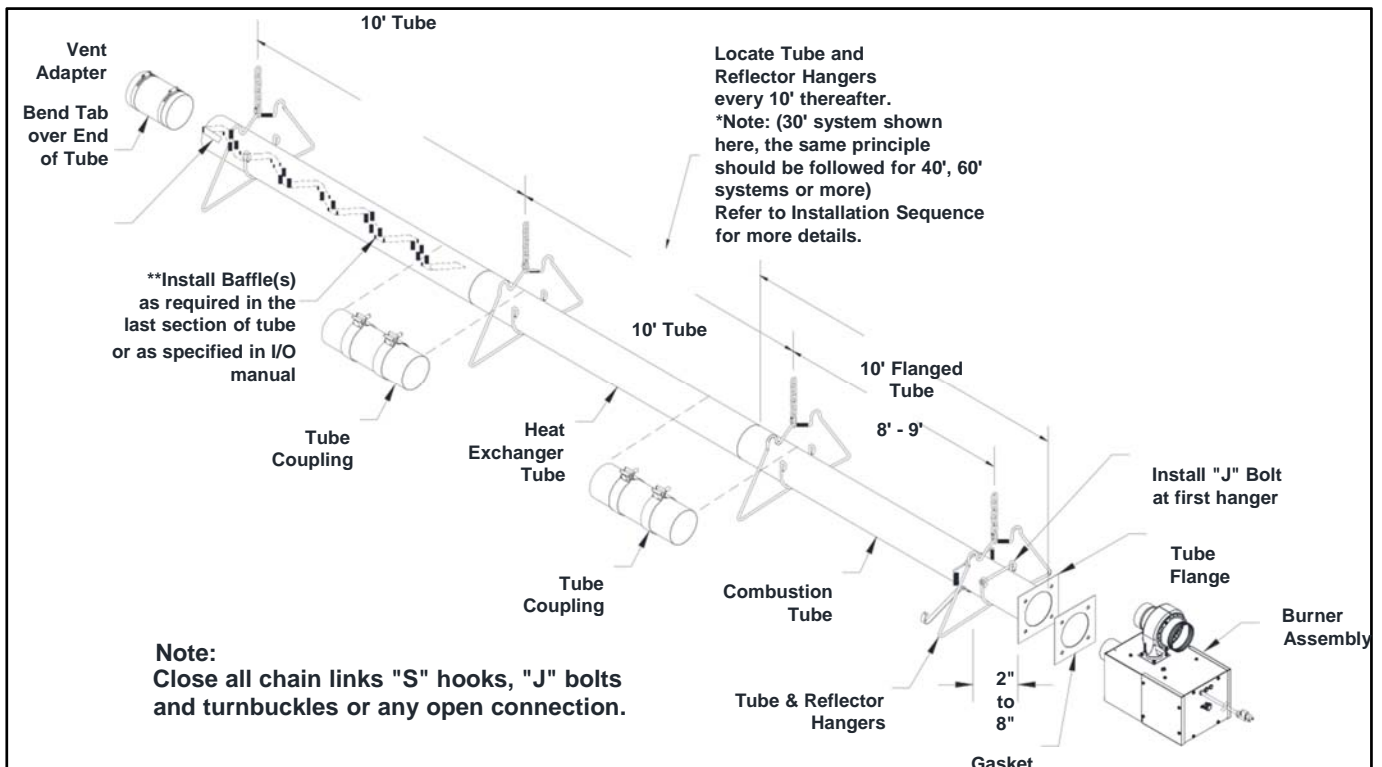

Figure 15: Overall view of Tubes and Reflector Hangers

# Venting / Combustion Air Ducting

---

## General Requirements

- Refer to the *National Fuel Gas Code*, ANSI Z223.1 (NFPA 54) in US, CAN/CGA B149.1 and B149.2 in Canada
- Series LTX Infrared Heaters may be installed vented or unvented.
- Series LTX Infrared Heaters may be vented horizontally or vertically using conventional venting materials.
- Optional outside air supply may be directed to the heater horizontally or vertically.

### IMPORTANT

- Maximum total vent length allowed for any model heater is 30'.
- Maximum total fresh air inlet duct length allowed for any model heater is 30'.
- Total of vent length plus outside air supply duct length cannot exceed 50' for any heater with minimum heat exchanger length.
- If condensation in the vent pipe or outside air supply duct is a problem, shorten or adequately insulate the section

**Note:** The above stated requirements assume a maximum of 2 elbows in the total combination of vent and air supply duct. Subtract 5' of allowable length for each elbow if 3 or more elbows are used.

## Un-Vented Operation

- Requirements for combustion air supply and dilution air vary by jurisdiction, building type and specific installation details. **See local codes for guidance.** In general, fresh air ventilation must be provided to the building space at **(4 cfm per 1000 BTU/Hr in US, 3 cfm per 1000 BTU/Hr in Canada)**
  - Optional outside air supply is not recommended for unvented heaters due to possible pressure imbalances in the building space.
  - Ensure that minimum combustible clearances are maintained for unvented heaters. Refer to Table 2, for required clearance dimensions.
-

## Vented Operation

In all cases, be sure vent pipes and outside air supply ducts are sealed with approved sealant, such as high temperature RTV silicone. Double wall venting (B vent) may not require sealant.

### Horizontal Venting

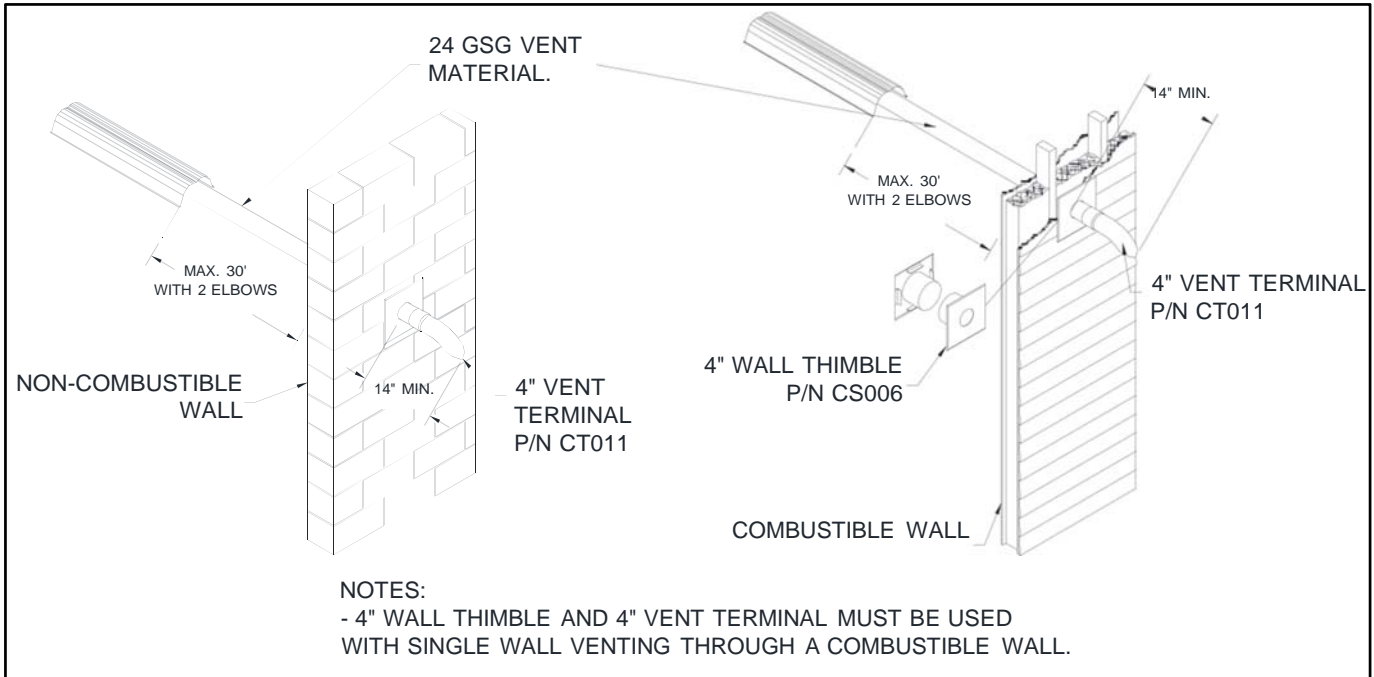

Figure 27: Horizontal Venting

### Vertical Venting

- Minimum vent pipe size is 4" for an individual heater. Additional vent pipe sizes as required to accommodate multiple heaters venting through a common roof vent are defined in the appropriate gas installation code. (Refer to common venting section below).
- Use of an approved thimble to pass through combustible roof materials is required.
- Use of an approved vent cap is required.

### Common Vertical Venting

- Common vent sizing information is defined in the appropriate gas installation code (Refer to ANSI Z223.1 in US, and CAN/CGA B149.1 and B149.2 in Canada)

# Venting / Combustion Air Ducting

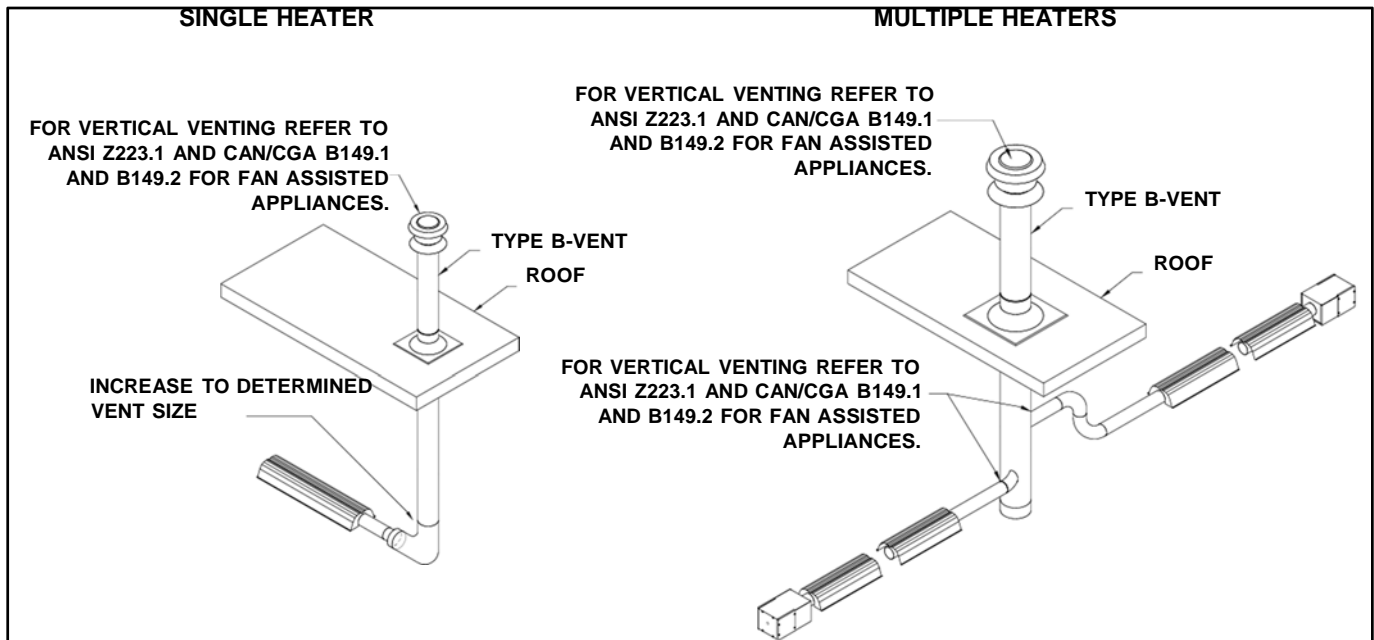

Figure 28: Vertical / Common Venting

## Common Horizontal Venting

- Refer to Figure 29 for detailed Common Horizontal Venting guidelines.

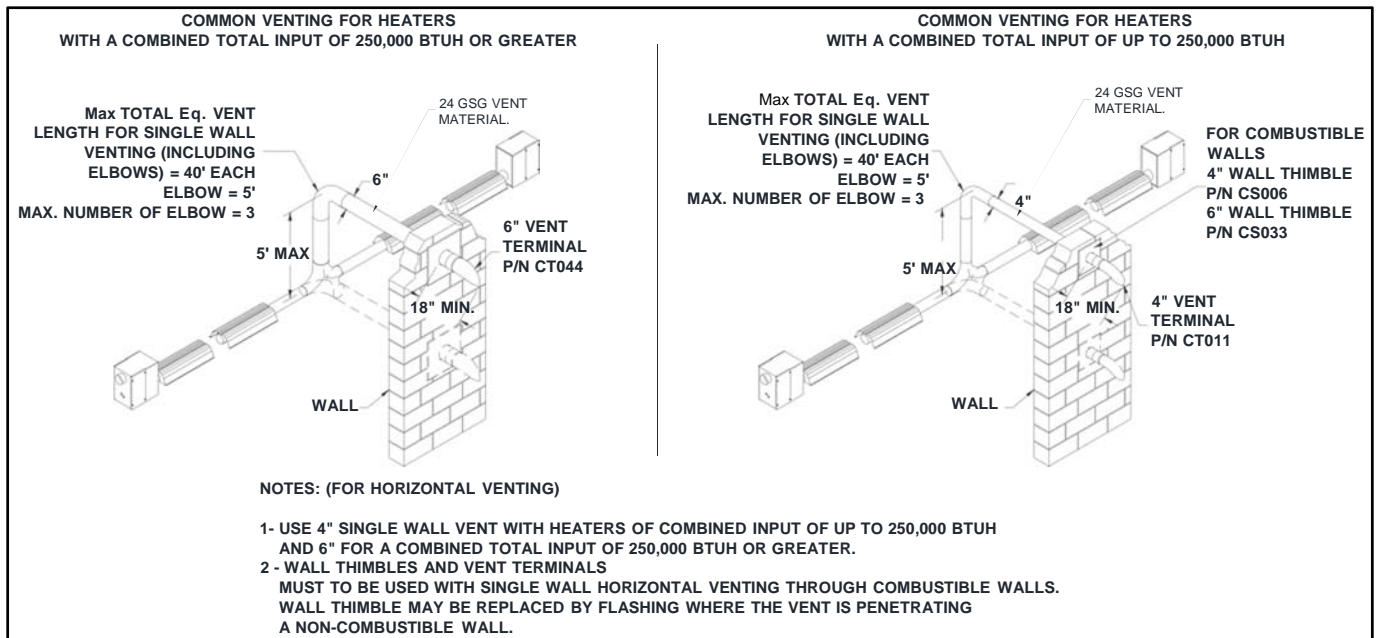

Figure 29: Common Horizontal Venting

# Electrical Wiring

## General Requirements

Heaters are normally controlled by line voltage (120V) or low voltage (24V) thermostats. Line voltage thermostats are wired directly while low voltage thermostats use a relay. In all cases, heaters must be grounded in accordance with the *National Electric Code*, ANSI/NFPA 70 in the US, and the *Canadian Electric Code*, CSA C22.1 in Canada, and must comply with all local requirements. Heaters may also be controlled with a manual line switch or timer switch in place of the thermostat. Refer to Figure 33 for guidance on electrical wiring of heaters.

If any of the original wire as supplied with the heater must be replaced, it must be replaced with wiring having a rating of at least 105°C temperature service and 600 volts capability.

Wiring Diagram Series 750 LTX

